

GREELEY SADDLE CLUB

Showmanship - Age Groups 5 & Under, 6-9, & 10-13

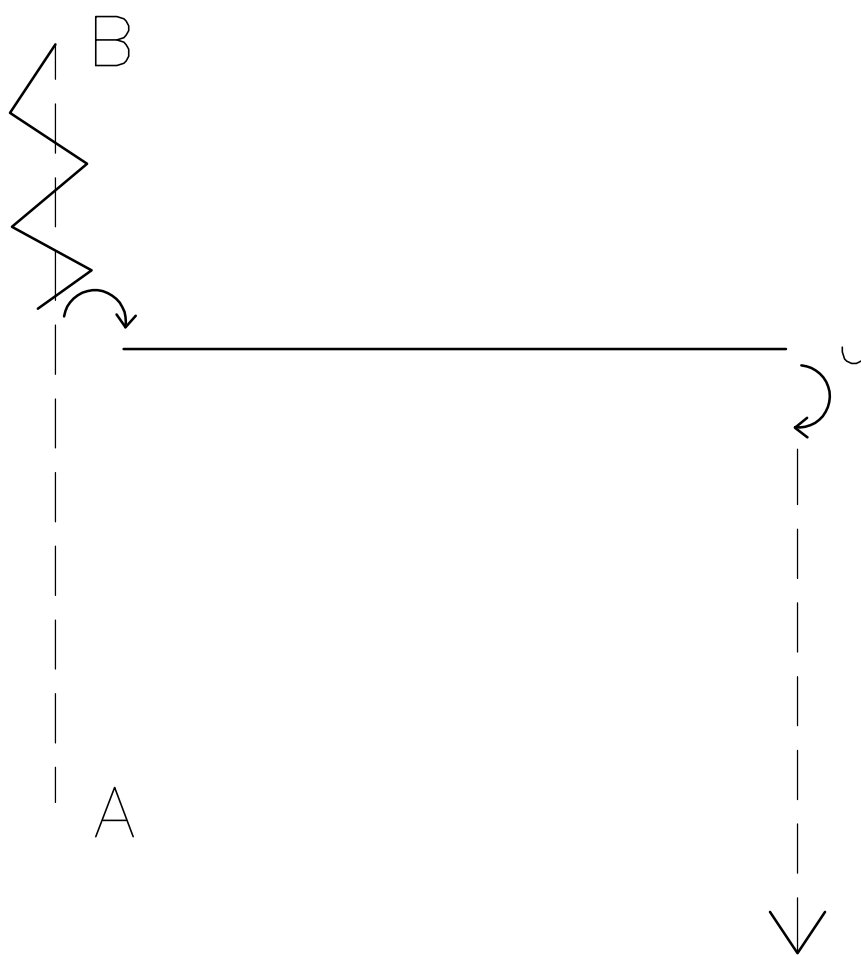

1. Start at A.
2. Trot to B and stop.
3. Back until even with the Judge.
4. Perform a 90° turn. Walk to the Judge.
5. Stop and set up for inspection.
6. When dismissed, complete a 90° turn and trot to line up.

GREELEY SADDLE CLUB

Showmanship - Age Groups 14-18, 19-39, 40 & Over

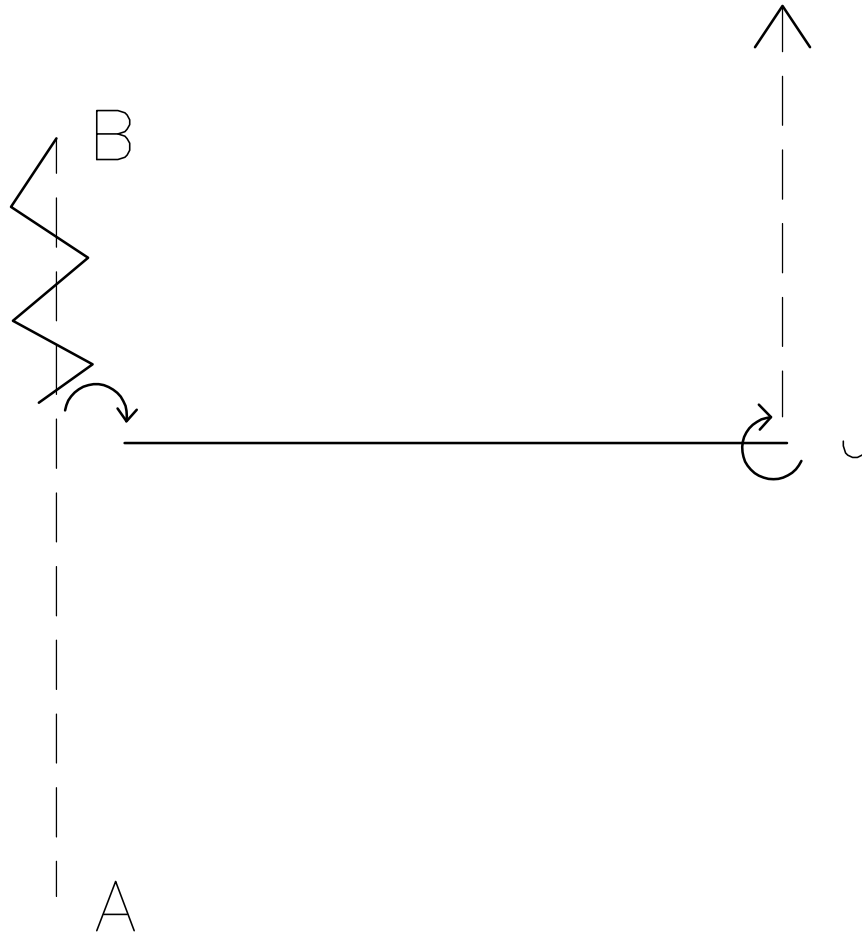

1. Start at A.
2. Trot to B and stop.
3. Back until even with the Judge.
4. Perform a 90° turn. Walk to the Judge.
5. Stop and set up for inspection.
6. When dismissed, complete a 270° turn and trot to line up.

GREELEY SADDLE CLUB

English Equitation - All Ages

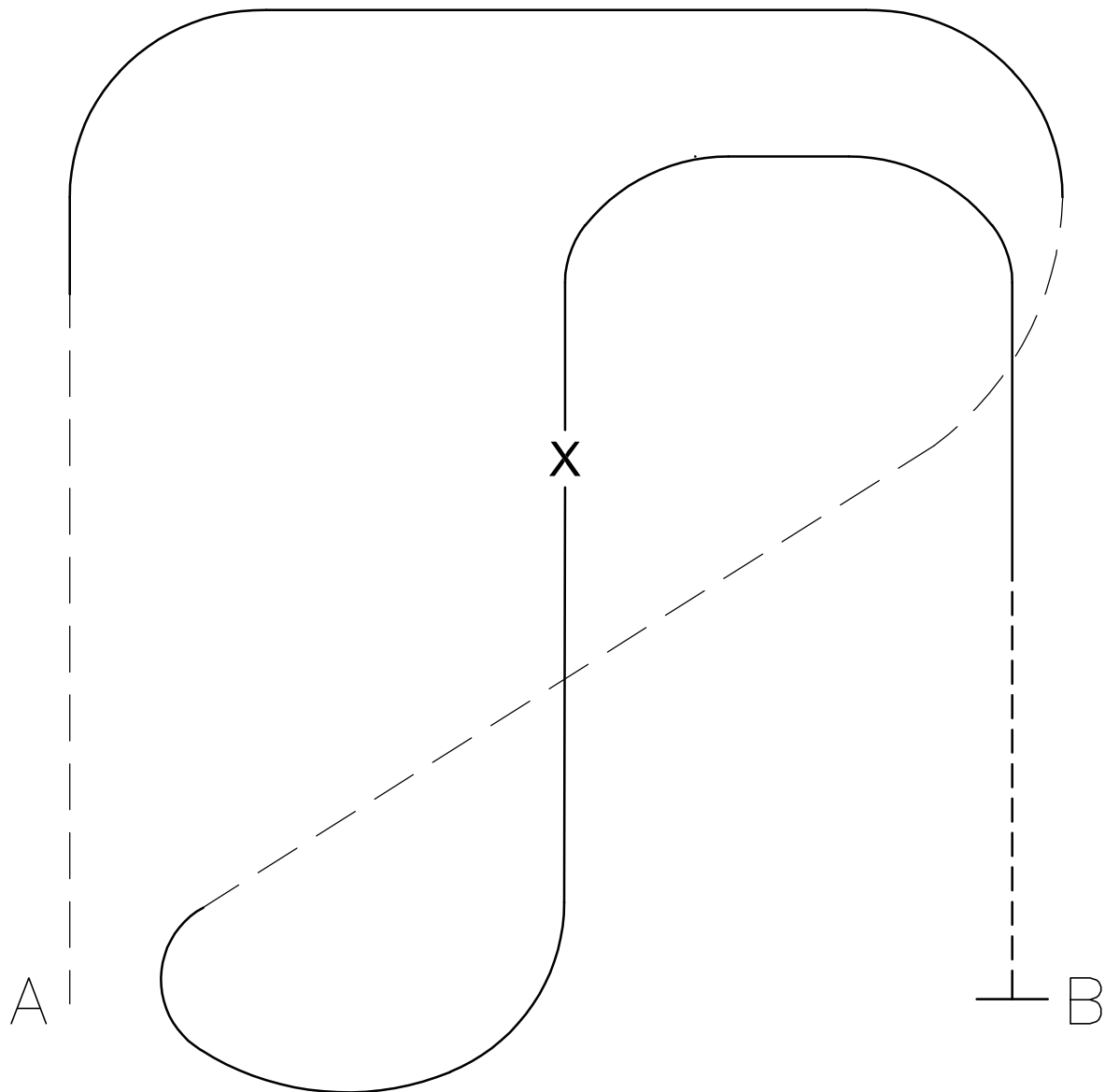

1. **Start at A.**
2. **Posting trot on the left diagonal from A.**
3. **Pick up a right lead canter and canter around as shown.**
4. **Breakdown to a trot, and post on the right diagonal across towards A.**
5. **Pick up a left lead canter and turn up the arena between A and B as shown.**
6. **Complete a simple lead change and canter on the right lead back around.**
7. **Break down to a collected sitting trot to B. Stop.**

GREELEY SADDLE CLUB

Horsemanship - Age Groups 6-9 & 10-13

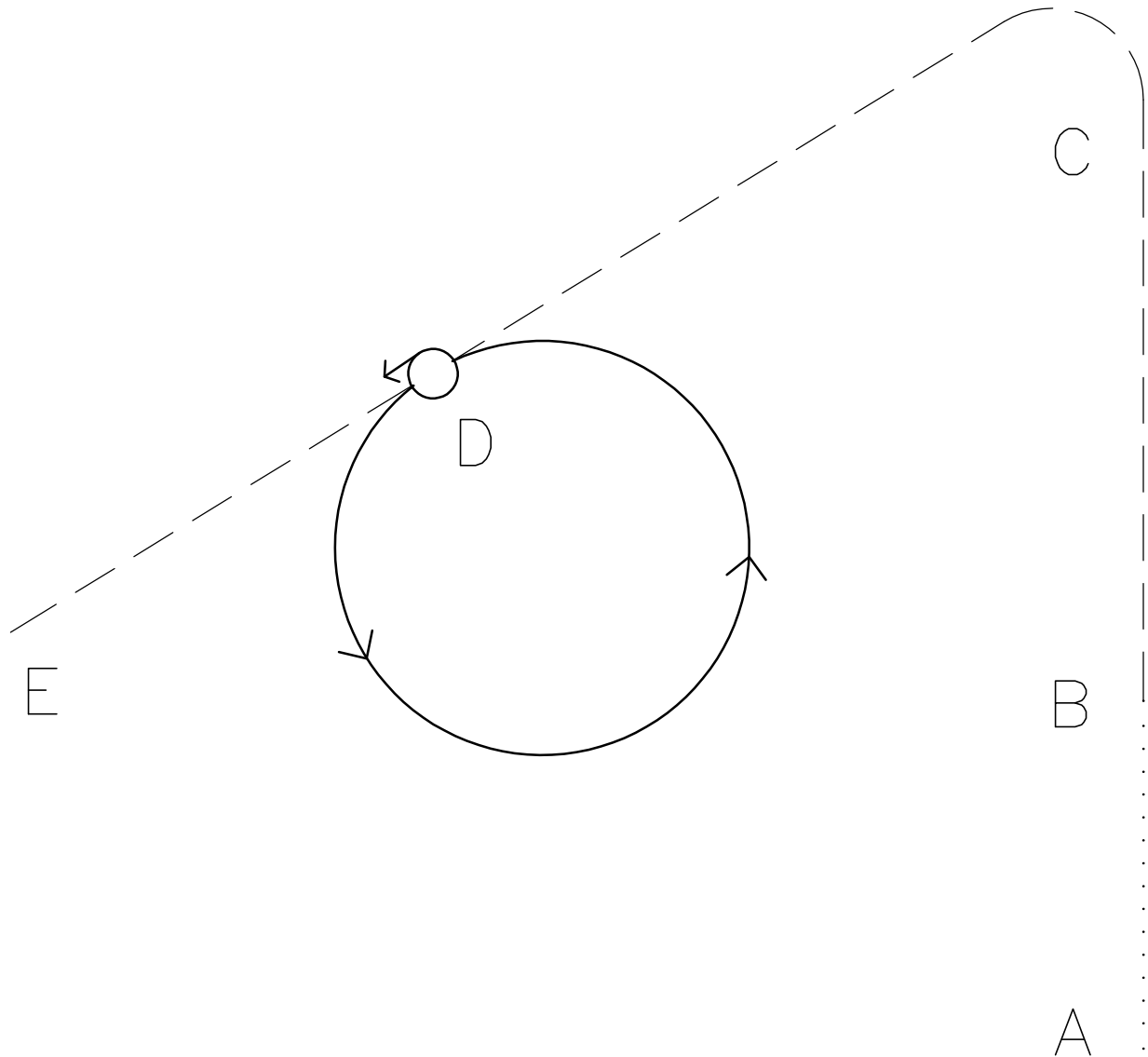

1. Walk from A to B.
2. At B, jog to and around C to D.
3. Lope a circle on the left lead around D.
4. Stop at D. Complete a 360° turn to the left.
5. Jog to E. Stop.

GREELEY SADDLE CLUB

Horsemanship - Age Groups 14-18, 19-39, 40 & Over

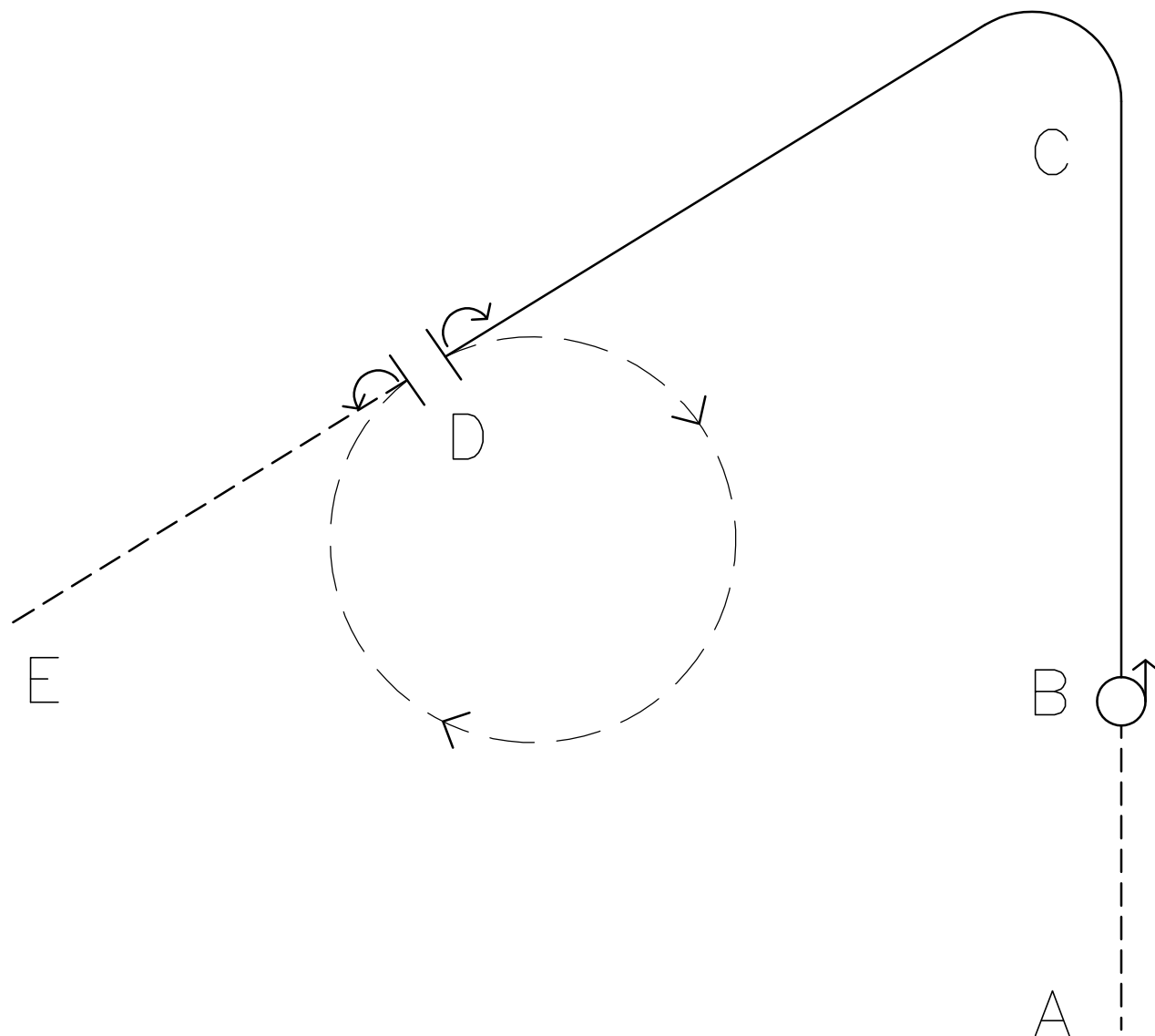

1. Jog from A to B.
2. Stop at B and complete a 360° turn to the left.
3. Lope to and around C on the left lead.
4. Stop at D. Complete a 180° turn to the right.
5. Extended jog a circle around D.
6. Stop at D. Complete a 180° turn to the left.
7. Jog to E. Stop.

GREELEY SADDLE CLUB

Reining - Age Group 6-9

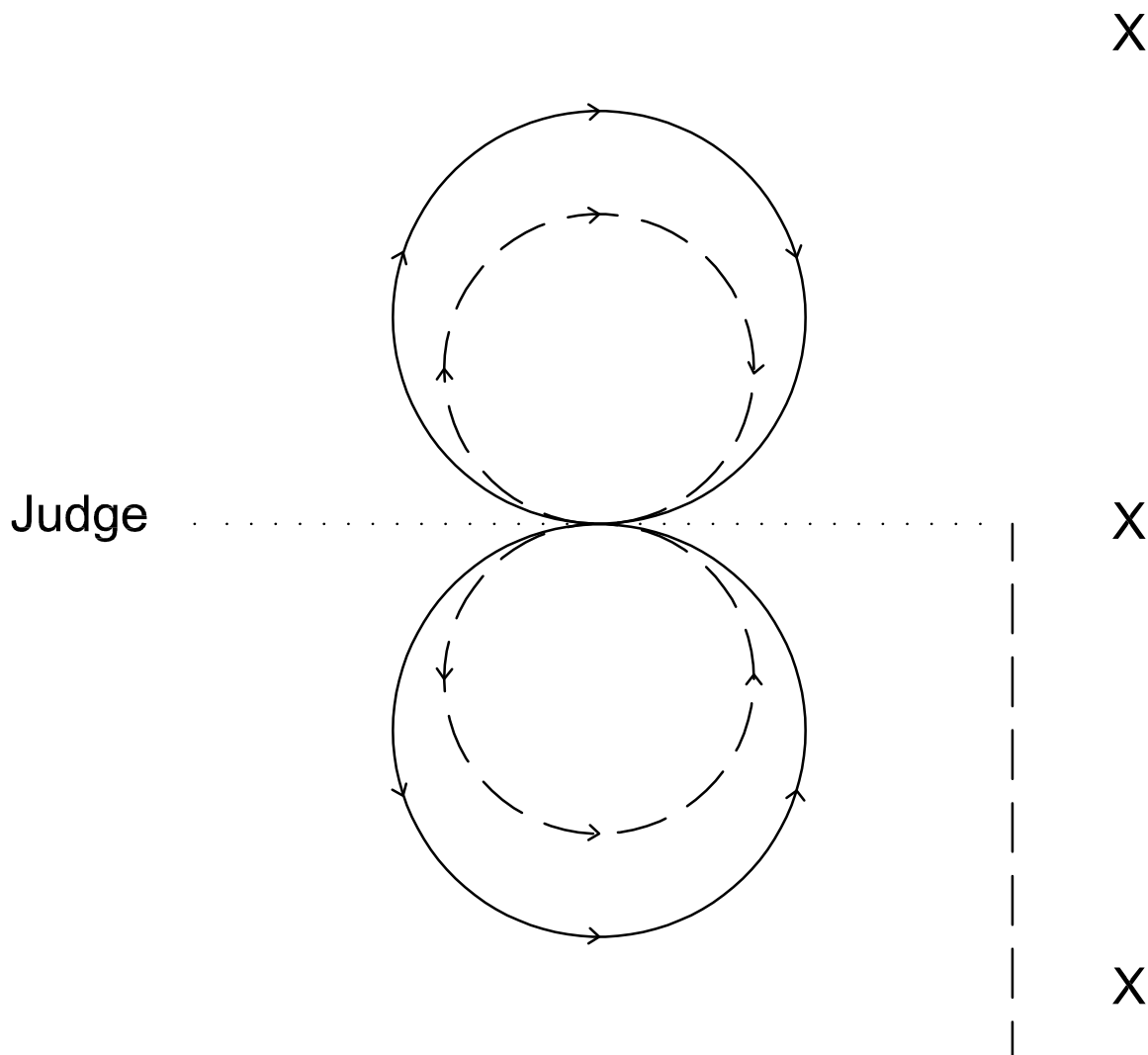

1. Trot in a straight line to the center marker, at least 20 feet from the rail.
2. Gradual stop through the walk.
3. Turn left, walk to center.
4. Trot a circle to the right.
5. Lope a circle to the right.
6. At the center, slow to a trot and trot a circle to the left.
7. Lope a circle to the left. At the center slow to a walk.
8. Walk to the judge for inspection.

GREELEY SADDLE CLUB

Reining - Age Groups 10-13, 14-18, 19-39, & 40 & Over

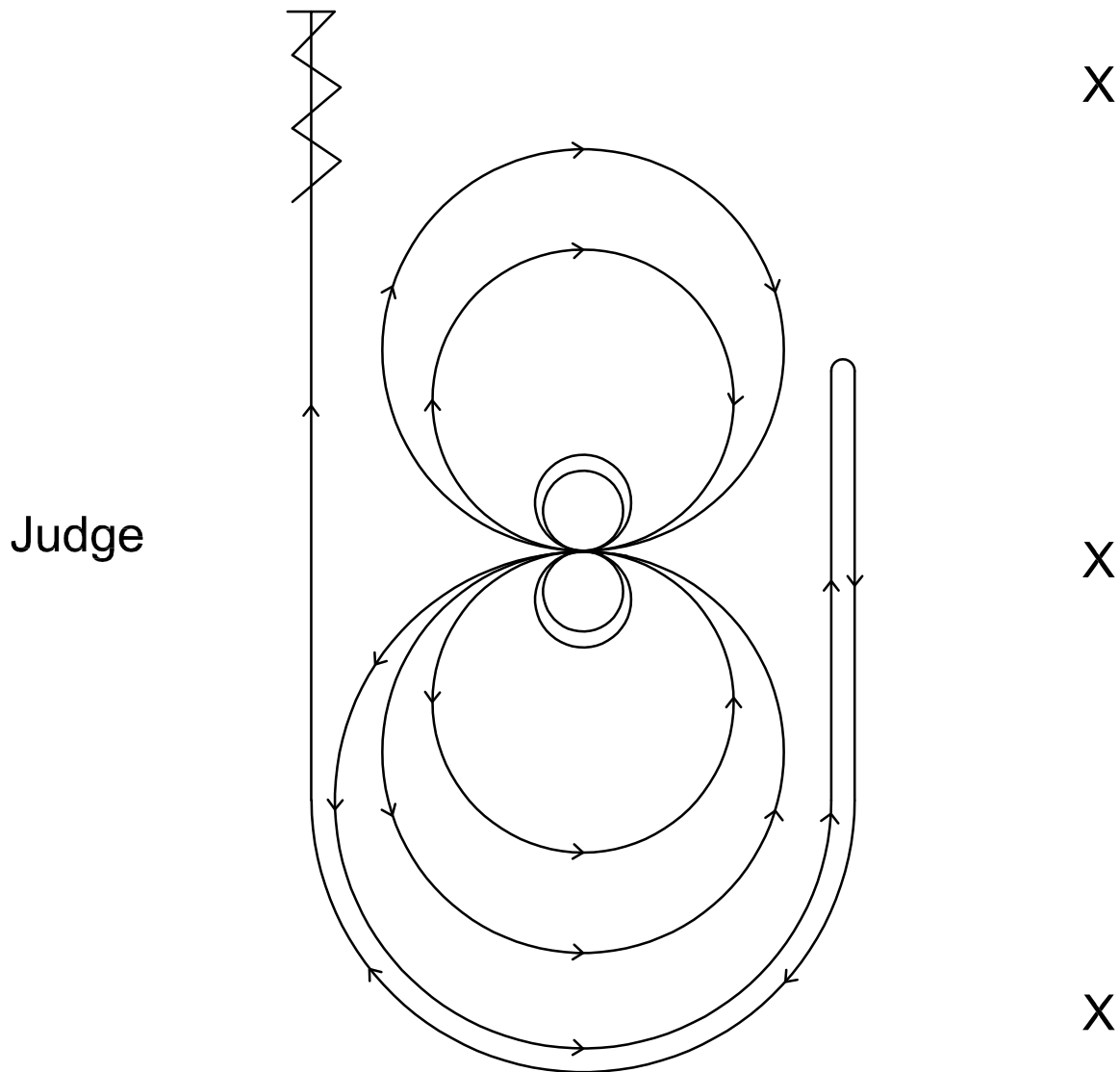

1. Jog to the center of the arena and face the judge on the left fence waiting to start your pattern.
2. Beginning on the left lead, complete two circles to the left. The first should be smaller and slower than the second. Stop at the center of the arena. Hesitate.
3. Complete two spins to the left. Hesitate.
4. Beginning on the right lead, complete two circles to the right. The first should be smaller and slower than the second. Stop at the center of the arena. Hesitate.
5. Complete two spins to the right. Hesitate.
6. Beginning on the left lead, go around the end of the arena, run down the right side of the arena past the center marker, stop and roll back right.
7. Continue around the end of the arena to run down the left side of the arena past the end marker. Stop and back up.

GREELEY SADDLE CLUB

Trail - Age Groups 5 & Under, 6-9, & Novice

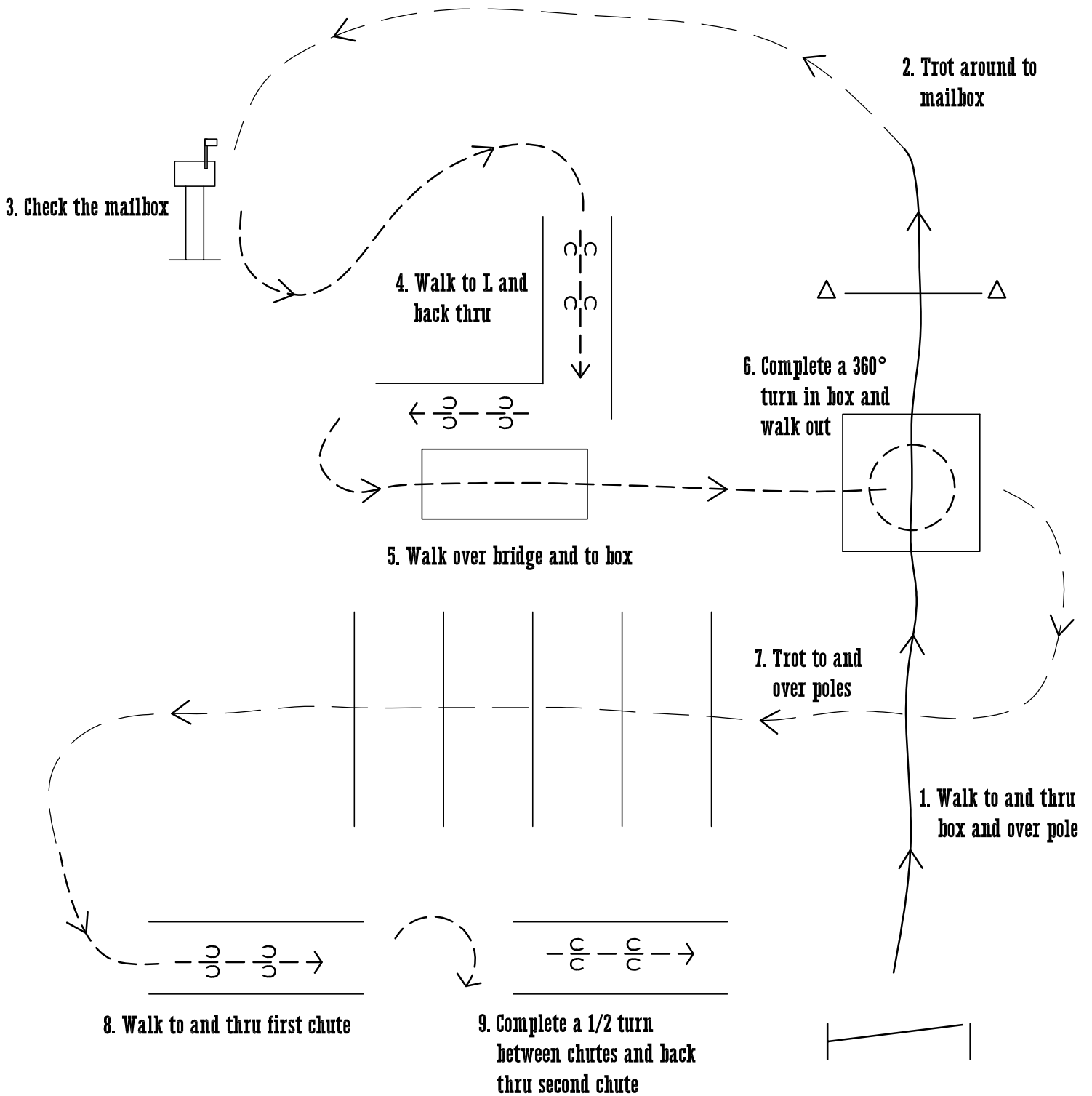

GREELEY SADDLE CLUB

Trail - Age Groups 10-13, 14-18, 19-39, 40 & Over

