

GREELEY SADDLE CLUB

Ranch Riding - Green Horse and Youth 13 & Under

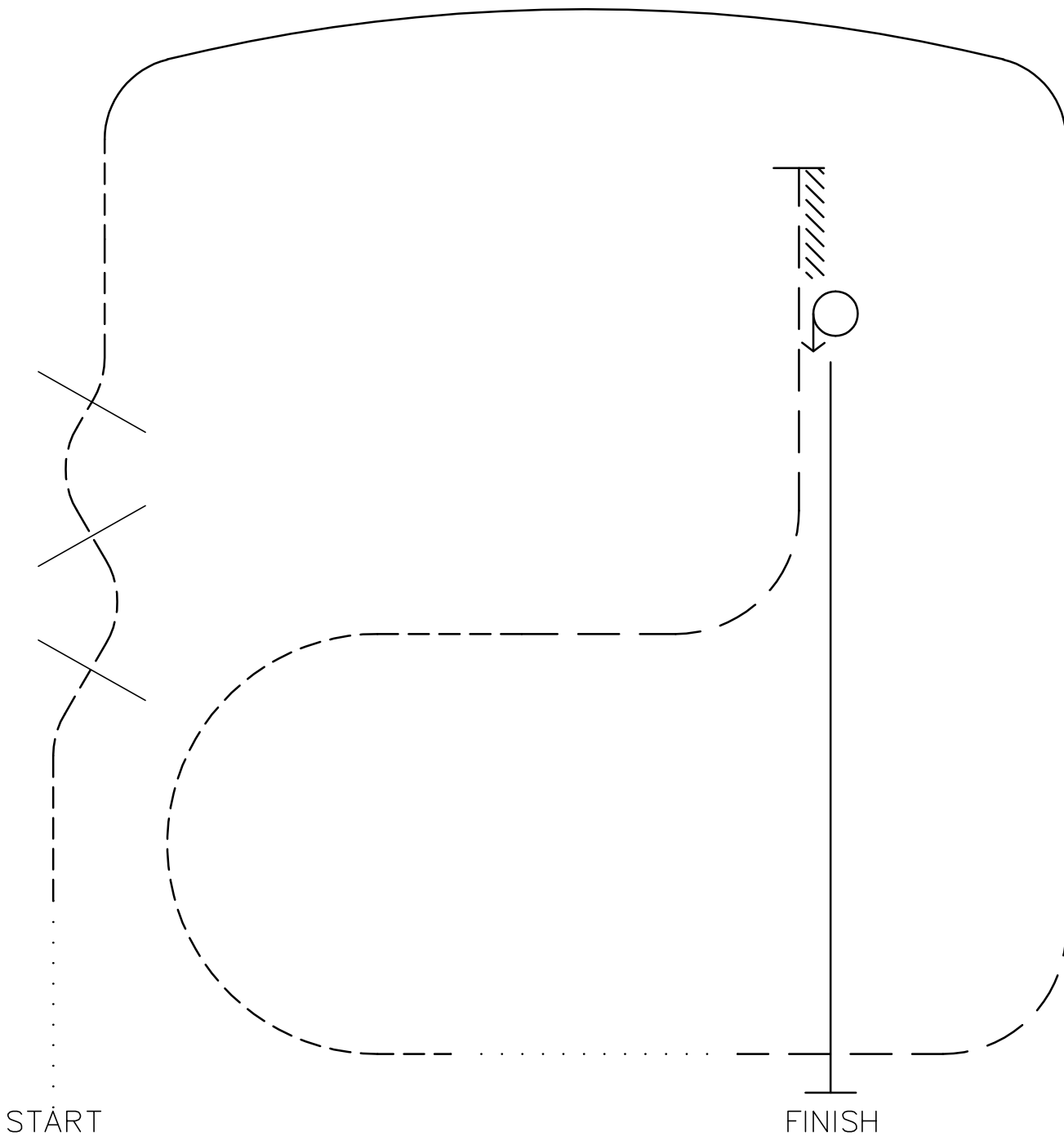

- | | | | |
|----|---------------------------------------|-----|------------------------------|
| 1. | Walk | 6. | Trot around a half circle |
| 2. | Trot over logs | 7. | Extended trot as shown |
| 3. | Lope right lead around arena end | 8. | Stop & back one horse length |
| 4. | Extended trot down & around arena end | 9. | 1 & 1/2 turns to the left |
| 5. | Walk | 10. | Lope left lead & stop |

GREELEY SADDLE CLUB

Ranch Riding - Youth 14-18, Amateur, Open

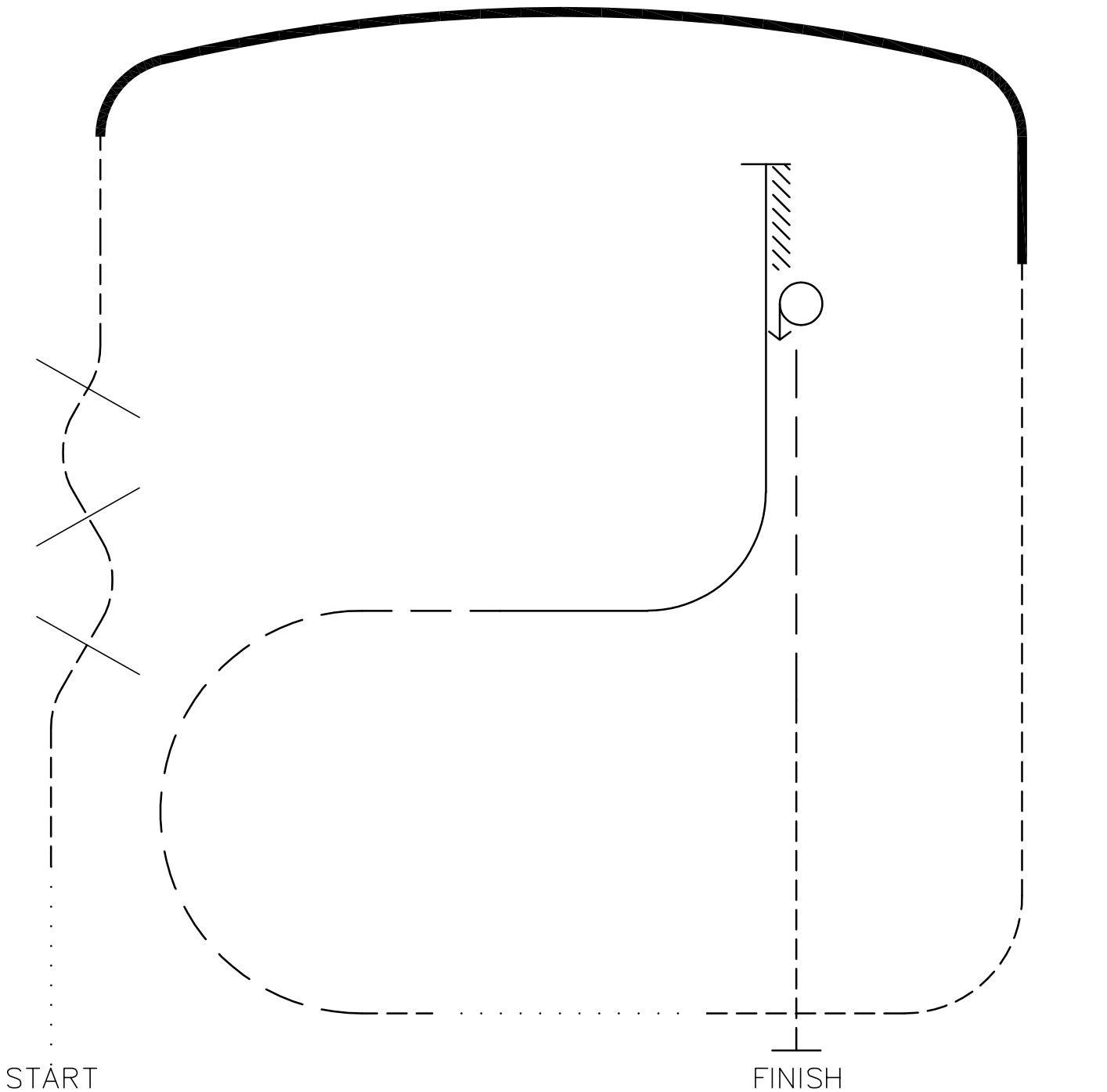

START

FINISH

- | | |
|--|--|
| 1. Walk | 6. Extended trot around a half circle |
| 2. Trot over logs | 7. Lope left lead as shown |
| 3. Extended lope right lead around arena end | 8. Stop & back one horse length |
| 4. Trot down & around arena end | 9. 1 & 1/2 turns to the left |
| 5. Walk | 10. Extended trot halfway to finish & regular trot remainder. Stop |

GREELEY SADDLE CLUB

Ranch Reining - Green Horse and Youth 13 & Under

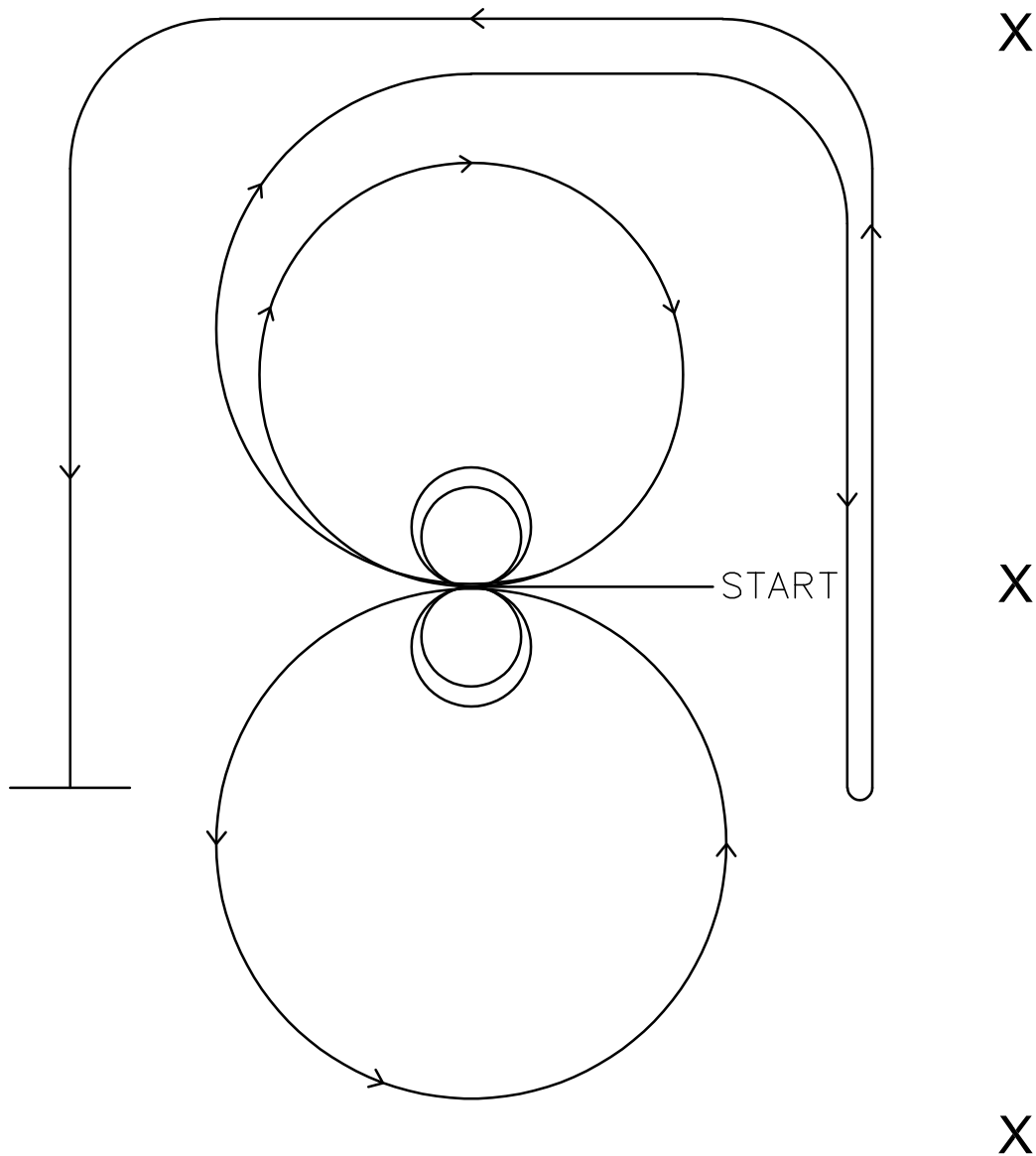

1. Trot to the center of the arena to start. Begin on the right lead and complete one small and slow circle to the right. Stop at the center.
2. Complete 2 spins right.
3. Lope a larger and faster circle to the left in the left lead. Stop at the center.
4. Complete 2 spins left.
5. Start loping a circle to the right in the right lead and continue around the end of the arena and past the center marker.
6. Stop & perform a left rollback.
7. Lope back around the end of the arena on the left lead. Run down past the center marker & stop.

GREELEY SADDLE CLUB

Ranch Reining - Youth 14-18, Amateur, Open

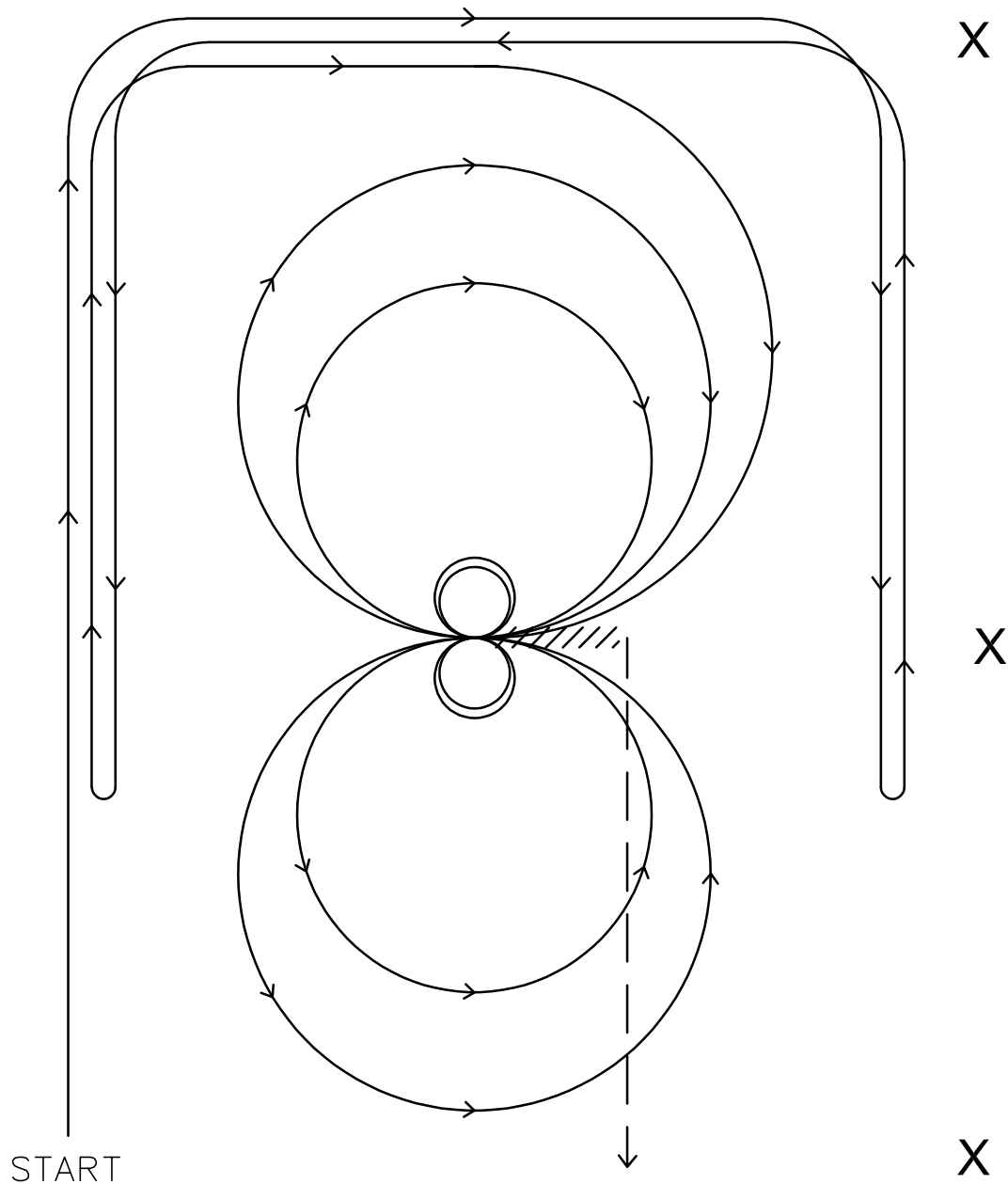

1. Start on the left side of the arena. Lope on the right lead around the end and run past the center marker. Stop. Roll back left.
2. Lope on the left lead back around the end of the arena. Run past the center marker. Stop. Roll back right.
3. Lope back around the end and close into a circle to the right at the center marker. Complete 2 circles on the right lead with the first one small slow and the second larger and faster. Stop at the center.
4. Complete 2 spins to the right.
5. On the left lead, complete 2 circles to the left with the first one larger and faster and than the second one. Stop at the center.
6. Complete 2 spins to the left. Hesitate.
7. Back 8-10 feet. Exit the arena at a trot.

GREELEY SADDLE CLUB

Ranch Trail - 5 & Under & Novice Walk/Trot

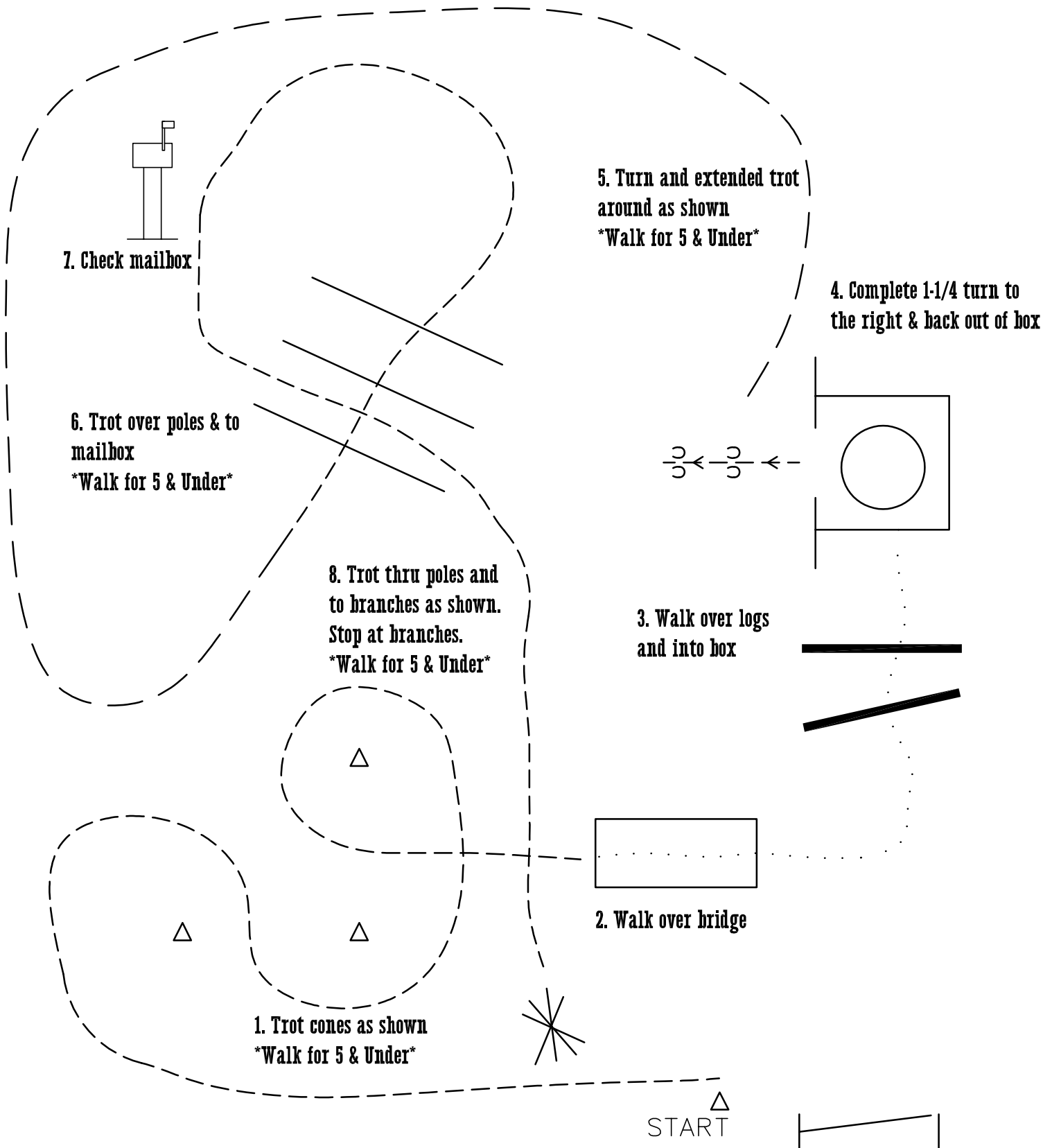

GREELEY SADDLE CLUB

Ranch Trail - Green Horse and Youth 13 & Under

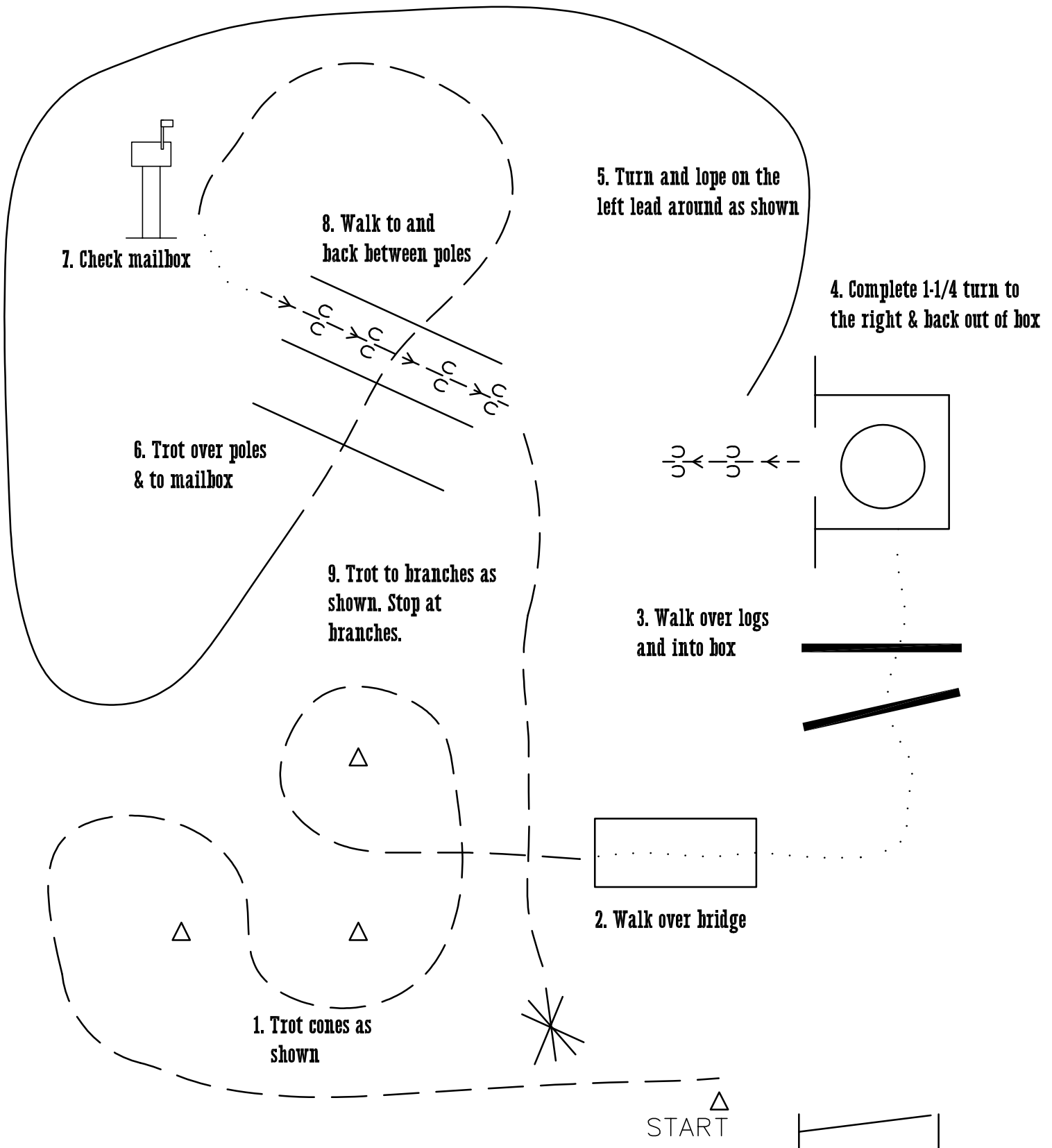

GREELEY SADDLE CLUB

Ranch Trail - Youth 14-18, Amateur & Open

